

Unbalanced modelling of STATCOM and SVC in hybrid load flow method

Alabri , Waleed; Jayaweera, Dilan

DOI:

[10.1109/ISGTEurope.2019.8905636](https://doi.org/10.1109/ISGTEurope.2019.8905636)

License:

None: All rights reserved

Document Version

Peer reviewed version

Citation for published version (Harvard):

Alabri , W & Jayaweera, D 2019, Unbalanced modelling of STATCOM and SVC in hybrid load flow method. in *Proceedings of 2019 IEEE PES Innovative Smart Grid Technologies Europe, ISGT-Europe 2019.*, 8905636, IEEE PES Innovative Smart Grid Technologies Europe (ISGT-Europe), Institute of Electrical and Electronics Engineers (IEEE), 2019 IEEE PES Innovative Smart Grid Technologies Europe (ISGT-Europe), Bucharest, Romania, 29/09/19. <https://doi.org/10.1109/ISGTEurope.2019.8905636>

[Link to publication on Research at Birmingham portal](#)

Publisher Rights Statement:

© 2019 IEEE. Personal use of this material is permitted. Permission from IEEE must be obtained for all other uses, in any current or future media, including reprinting/republishing this material for advertising or promotional purposes, creating new collective works, for resale or redistribution to servers or lists, or reuse of any copyrighted component of this work in other works.

General rights

Unless a licence is specified above, all rights (including copyright and moral rights) in this document are retained by the authors and/or the copyright holders. The express permission of the copyright holder must be obtained for any use of this material other than for purposes permitted by law.

- Users may freely distribute the URL that is used to identify this publication.
- Users may download and/or print one copy of the publication from the University of Birmingham research portal for the purpose of private study or non-commercial research.
- User may use extracts from the document in line with the concept of 'fair dealing' under the Copyright, Designs and Patents Act 1988 (?)
- Users may not further distribute the material nor use it for the purposes of commercial gain.

Where a licence is displayed above, please note the terms and conditions of the licence govern your use of this document.

When citing, please reference the published version.

Take down policy

While the University of Birmingham exercises care and attention in making items available there are rare occasions when an item has been uploaded in error or has been deemed to be commercially or otherwise sensitive.

If you believe that this is the case for this document, please contact UBIRA@lists.bham.ac.uk providing details and we will remove access to the work immediately and investigate.

Unbalanced Modelling of STATCOM and SVC in Hybrid Load Flow Method

Waleed Alabri

Dept. of Electronic, Electrical and System Engineering
University of Birmingham, UK
WAA790@bham.ac.uk

Dilan Jayaweera

Dept. of Electronic, Electrical and System Engineering
University of Birmingham, UK
D.Jayaweera@bham.ac.uk

Abstract— Modern power distribution systems are installed with a number of distributed power generation in the presence of Flexible AC Transmission System (FACTS) devices. Increased integration of distributed power generation makes the distribution system vulnerable to unbalanced operating conditions, meaning it would then require the support of FACTS for a smooth operation of the distribution system. Unbalanced power system operation requires an unbalanced load flow analysis in order to assess true system feasibility. This paper presents an innovative unbalance load flow analysis method with the presence of unbalanced operation of SVCs (Static Var Compensators) and STATCOMs (STATIC COMPensators). Unlike the existing methods, the proposed method applies reduced steps in the calculation, and the parameter limits are dynamically determined in an iterative process. Case studies demonstrate its improved convergence characteristics, reduced computing demand and the robustness of the solution.

Keywords— *Power Distribution System, Smart Power Distribution System, Unbalanced Load Flow, Voltage Unbalance*

I. INTRODUCTION

Increased integration of low-carbon power generation technologies potentially heighten the degree of voltage and current unbalance in power distribution systems. Unbalanced operations may develop several problems, including an increase in power system losses, issues with the coordination of power system protection equipment and consumer appliance damage [1]. Reactive power compensation based on power electronic devices such as Static Var Compensator (SVC) and Static Synchronous Compensator (STATCOM) considered as the most effective method to solve the problem of unbalanced voltage and to improve the power quality problem in power systems [2].

In most Newton-Raphson (N-R) method based power flow analysis, SVC and STATCOM control parameters were applied as independent variables, and their values were calculated by load flow iterative calculations [3]. Such approach requires several modifications to existing load flow algorithms and at times it makes non-convergence or computationally demanding. It also increases the size of the Jacobian and admittance matrices to accommodate the additional independent variables, and hence increase the computation time. The convergence of this method is found to be dependent on the initial values of control parameters of FACTS devices [4]. Moreover, in analysing an unbalanced three-phase system, most of the power flow models of SVC and STATCOM were based on Three-phase Power Injection Mismatches (TPIM), which performs poor in term of convergence compared with Three-phase Current Injection Mismatches (TCIM) [5].

A simplified model of SVC and STATCOM in a balanced N-R load flow has been proposed in [6] and [7] to improve the convergence characteristics and computing time. The power mismatch equation was used to represent SVC and STATCOM as a PV type bus (voltage controlled bus or active power and voltage magnitude known bus) with a specified voltage and zero generated active power, which keeps the original Jacobian matrix unchanged. Then, the parameter of voltage control devices can be calculated during the iteration process using less complicated equations. Recently some of FACTS devices have been used in power distribution systems, especially for voltage support [8]. Therefore, the models of STATCOM and SVC need to be re-addressed for power distribution system applications considering unbalance.

Divergence problems were also reported when TCIM was implemented for a three-phase load flow calculation in a heavily loaded network with PV type buses. This issue was solved in [9] however, as the improved models increase computing time because the number of required equations at each PV type bus is increased to three in this case. Recently a new depiction of PV buses has been suggested in [10] for the Current Injection load flow Method (CIM) considering the balanced load flow approach. In this implementation, the required number of equations was reduced from three to one, resulting in lesser number of iterations and computation time. However, this method is applicable only for power transmission systems and, accordingly, there is a need of some modifications to accommodate the unbalanced operation of power distribution systems.

This paper presents simplified models of three-phase STATCOM and SVC that are embedded into an unbalanced three phase load flow calculation. The new representation of a PV type bus presented in PCIM [10] is extended to an unbalanced three-phase power system. The advanced method of load flow together with FACTS device models decrease the complexity of the load flow calculation, improves the computing time, and reduces the number of iterations. The proposed Three-phase Power and Current Injection Hybrid Method (TPCIHM) is formulated in Section II. The proposed three phase models of SVC and STATCOM are described in sections III and IV. Tests and comparison of three phase modelling of STATCOM and SVC in the unbalanced three phase load flow method is analysed in section V. Section VI concludes the findings.

II. TPCIHM FORMULATION

The method proposed in this paper bridges two Newton-Raphson (N-R) methods; the current injection method and power injection method. The load (PQ bus type) buses are modelled as in the Three-phase Current Injection Method

(TCIM) [11], whereas the PV (Generator bus type) buses are modelled using Three-phase real Power Injection Mismatches (TPIM) [12]. The Newton-Raphson (N-R) method is used to find the voltage magnitude and angle at each bus by solving the nonlinear set of current and real power mismatch equations. In the N-R method, the linearized problem is formed through the Jacobian matrix J , as shown in (1).

$$\begin{bmatrix} \Delta(I_k^m)^{abc} \\ \Delta(I_k^r)^{abc} \\ \vdots \\ \Delta(P_m)^{abc} \\ \vdots \end{bmatrix} = -J \cdot \begin{bmatrix} \Delta(V_k^r)^{abc} \\ \Delta(V_k^m)^{abc} \\ \vdots \\ \Delta\delta_m^{abc} \\ \vdots \end{bmatrix} \quad (1)$$

Where the three phase current injection mismatch equations for PQ type buses are:

$$\Delta(I_i^r)^p = \frac{(P_i^{sp})^p (V_i^r)^p + (Q_i^{sp})^p (V_i^m)^p}{((V_i^r)^p)^2 + ((V_i^m)^p)^2} - \sum_{j=1}^n \sum_{q=a,b,c} (G_{ij}^{pq} (V_j^r)^q - B_{ij}^{pq} (V_j^m)^q) \quad (2)$$

$$\Delta(I_i^m)^p = \frac{(P_i^{sp})^p (V_i^m)^p - (Q_i^{sp})^p (V_i^r)^p}{((V_i^r)^p)^2 + ((V_i^m)^p)^2} - \sum_{j=1}^n \sum_{q=a,b,c} (G_{ij}^{pq} (V_j^m)^q + B_{ij}^{pq} (V_j^r)^q) \quad (3)$$

and the three phase real power injection mismatch equation for PV buses is:

$$\Delta(P_i)^p = (P_i^{sp})^p - \sum_{j=1}^n \sum_{q=a,b,c} |V_i^p| |V_j^q| (G_{ij}^{pq} \cos(\delta_i^p - \delta_j^q) - \delta_j^q) + B_{ij}^{pq} \sin(\delta_i^p - \delta_j^q) \quad (4)$$

where

$$(P_i^{sp})^p = P_{gi}^p - P_{li}^p \quad (5)$$

$$(Q_i^{sp})^p = Q_{gi}^p - Q_{li}^p \quad (6)$$

$p, q \in \{a, b, c\}$ - represent the three phases

$P_{gi}^p, Q_{gi}^p, P_{li}^p, Q_{li}^p$ - the specified real and reactive power of generators and loads at bus i for phase p .

$Y_{ij}^{pq} = G_{ij}^{pq} + jB_{ij}^{pq}$ - is the bus admittance matrix element.

The sub-matrices of Jacobian J element corresponding to PQ buses only $(\frac{\partial \Delta(I_i^m)^{abc}}{\partial (V_j^r)^{abc}}, \frac{\partial \Delta(I_i^m)^{abc}}{\partial (V_j^m)^{abc}}, \frac{\partial \Delta(I_i^r)^{abc}}{\partial (V_j^r)^{abc}}, \frac{\partial \Delta(I_i^r)^{abc}}{\partial (V_j^m)^{abc}})$ are

identical to the TCIM [11]. The elements of the Jacobian matrix which correspond to PQ and PV buses ($i \neq j$) can be computed as follows:

$$\frac{\partial \Delta(I_i^m)^{abc}}{\Delta \delta_j^{abc}} = -V_j^{abc} (G_{ij}^{abc} \cos \delta_j^{abc} - B_{ij}^{abc} \sin \delta_j^{abc}) \quad (7)$$

$$\frac{\partial \Delta(I_i^r)^{abc}}{\Delta \delta_j^{abc}} = V_j^{abc} (G_{ij}^{abc} \sin \delta_j^{abc} + B_{ij}^{abc} \cos \delta_j^{abc}) \quad (8)$$

$$\frac{\partial \Delta(P_i)^{abc}}{\partial (V_j^r)^{abc}} = -((V_i^r)^{abc} G_{ij}^{abc} + B_{ij}^{abc} (V_i^m)^{abc}) \quad (9)$$

$$\frac{\partial \Delta(P_i)^{abc}}{\partial (V_j^m)^{abc}} = -((V_i^m)^{abc} G_{ij}^{abc} - B_{ij}^{abc} (V_i^r)^{abc}) \quad (10)$$

The last element of the Jacobian matrix which is corresponding to PV buses $(\frac{\partial \Delta(P_i)^{abc}}{\Delta \delta_j^{abc}})$ are identical to the

elements used in TPIM [12]. After calculating the Jacobian matrix and mismatch equations, the voltage magnitude and angle for PQ buses and the only voltage angle for PV buses are needed to be calculated and updated during the iteration process. Therefore, for PQ buses;

$$\begin{aligned} (V_{k+1}^r)^{abc} &= (V_k^r)^{abc} + \Delta(V_k^r)^{abc} \\ (V_{k+1}^m)^{abc} &= (V_k^m)^{abc} + \Delta(V_k^m)^{abc} \end{aligned} \quad (11)$$

$$\begin{aligned} |V_{k+1}^{abc}| &= \sqrt{((V_{k+1}^r)^{abc})^2 + ((V_{k+1}^m)^{abc})^2} \\ \delta_{k+1}^{abc} &= \tan^{-1} \left(\frac{(V_{k+1}^m)^{abc}}{(V_{k+1}^r)^{abc}} \right) \end{aligned} \quad (12)$$

For PV buses;

$$\delta_{k+1}^{abc} = \delta_k^{abc} + \Delta \delta_k^{abc} \quad (13)$$

III. STATCOM MODELING

Based on the operating principle of the STATCOM, the three-phase equivalent model of STATCOM is shown in Fig.1. The impedance (Z_{sh}) represents the mutual and self-impedance of STATCOM's transformer and converter. The controllable voltage source ($V_{sh} \angle \delta_{sh}$) is used to regulate the voltage at the bus where the STATCOM is connected. However, the magnitude of STATCOM voltage is limited by the maximum and minimum values, while its phase angle can vary from 0 to 2π .

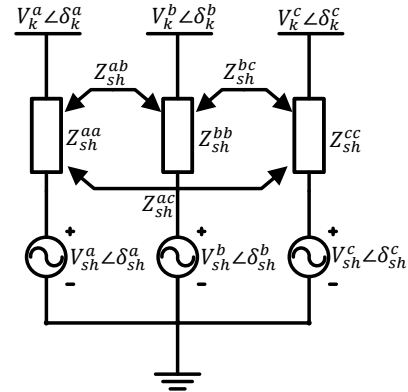

Figure 1. Three-phase STATCOM equivalent circuit

Under ideal conditions, it could be considered that there is an insignificant real power exchange between the AC system and the STATCOM, and only the reactive power can be exchanged between them. Therefore, the STATCOM connected bus is represented as a PV type bus with a specified voltage magnitude and zero real power generation when it operates within limits. The parameters of the STATCOM model for each phase shown in Fig.1 can be calculated using (14), which can be used to check the operation limits of STATCOM at the end of each iteration.

$$E_{sh}^p = E_k^p + \sum_{q=a,b,c} Z_{sh}^{pq} \left(\frac{S_{sh}^q}{E_k^q} \right)^* \quad (14)$$

Where

$$\begin{aligned} p \& q = \{a, b, c\} \\ E_k^p &= V_k^p \angle \delta_k^p \\ E_{sh}^p &= V_{sh}^p \angle \delta_{sh}^p \\ S_{sh}^p &= P_{sh}^p + jQ_{sh}^p \end{aligned}$$

As there is no active power generation or absorption from STATCOM, $P_{sh}^p = 0$, Q_{sh}^p can be calculated during the iteration process using (15).

$$Q_{sh}^p = \sum_{j=1}^n \sum_{q=a,b,c} |V_k^p| |V_j^q| \left(G_{kj}^{pq} \sin(\delta_k^p - \delta_j^q) - B_{kj}^{pq} \cos(\delta_k^p - \delta_j^q) \right) + Q_{k-load}^p \quad (15)$$

If the injected voltage V_{sh}^p of STATCOM violates its limits ($V_{sh-min}^p < V_{sh}^p < V_{sh-max}^p$), the bus type is changed to a load bus (PQ) and the generated or absorbed reactive power results from the violated limit. Therefore,

$$\begin{aligned} V_{sh}^p &= V_{sh-max}^p, \text{ if } V_{sh}^p \geq V_{sh-max}^p \\ V_{sh}^p &= V_{sh-min}^p, \text{ if } V_{sh}^p \leq V_{sh-min}^p \end{aligned} \quad (16)$$

IV. SVC MODELING

Similar to STATCOM modelling, SVC can also be modelled as a PV type bus, and either the SVC's firing angle, α_{SVC} , or the SVC's equivalent susceptance, B_{SVC} , are considered as controlled variables. Their limits are then checked with the iteration calculations. The three-phase SVC consists of a delta-connected Thyristor Controlled Reactor (TCR) in parallel with a star connected capacitor bank. For power flow analysis the capacitor bank is transferred to a delta connection where the firing angle or total susceptance model is used [12]. The total susceptance model of the three-phase delta connected SVC is shown in Fig. 2.

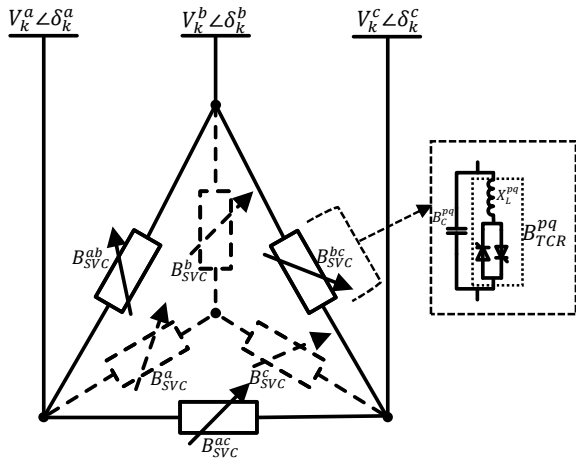

Figure 2. Three-phase SVC equivalent circuit

The parameters of the SVC model shown in Fig.2 considering star connections can be calculated at each iteration using (17).

$$B_{SVC}^p = \left(\frac{Q_{SVC}^p}{(V_k^p)^2} \right) \quad (17)$$

Q_{SVC}^p is calculated using (15). The parameters of the SVC model considering the delta connected can be calculated using star-delta transformation, as shown in (18).

$$B_{SVC}^{pq} = \frac{B^p B^q + B^p B^s + B^q B^s}{B^s} \quad (18)$$

where $p \neq q \neq s \in \{a, b, c\}$

If the parameters of SVC violate its limits, the bus type is changed to a load type bus (PQ) and the generated or absorbed reactive power is corresponded to the violated limit. It is also possible to calculate the thyristor firing angle α_{SVC} using (19).

$$\begin{aligned} B_{SVC}^{pq} &= B_C^{pq} - B_{TCR}^{pq} \\ &= \frac{B_c^p B_c^q}{\sum_{j=a,b,c} B_c^j} - \frac{(2(\pi - \alpha^{pq}) + \sin(2\alpha^{pq}))}{\pi X_L^{pq}} \end{aligned} \quad (19)$$

where $p \neq q$

V. CASE STUDIES

There are three case studies in which the first case study is to investigate the computing time and convergence characteristics of a proposed TPCIHM. The second and the third case studies are to validate STATCOM and SVC models and to check the performance in improving voltage unbalance. All load flow algorithms were implemented on MATLAB (R2017a) and the relative convergence tolerance ϵ was set to 1.E-12. The maximum number of iterations was set to 50. All tests were performed on an Intel computer i7-6700 at 3.4 GHz CPU and 12GB RAM.

A. Case Studies on TPCIHM

Two unbalanced distribution networks, IEEE 13-bus test feeder and IEEE 37-bus test feeder [13] were used to test the performance of the proposed load flow methods and compare with the TPIM used in [12] and TCIM used in [9]. The comparison was intended to evaluate the rate of convergence and execution time considering the number of PV bus connections. As a new representation of the PV buses proposed here, a number of generator buses were added to both tested feeders. All loads are assumed to be constant power load type and are connected in a Wye configuration.

All load flow methods converge at the 5th iteration. The average computation time for different load flow methods were investigated and presented in Table 1. It can be observed that the TPCIHM method keeps the same number of iterations; however, the average computation time is less compared with other N-R methods.

TABLE 1. COMPARISON OF COMPUTING TIME

	Executing Time (s)	
	IEEE 13	IEEE 37
TPIM	0.01685	0.15280
TCIM	0.01240	0.08385
TPCIHM	0.01105	0.08365

B. Case Studies on SVC and STATCOM Model

The objective of this study is to validate the result obtained from the developed three-phase SVC and STATCOM models and to compare the convergence performance with other published models. A 5-bus network shown in Fig. 3 was used to validate the three phase SVC and STATCOM models and to compare them with models used in [12]. For the purpose of this study, an imbalance in operating conditions was introduced into the test network by altering the load at each phase.

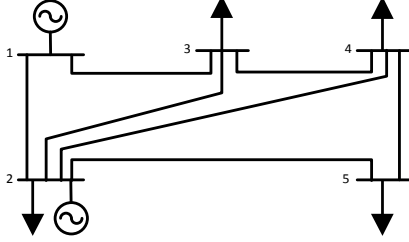

Figure 3. The five-bus test network [12]

First, the unbalanced three phase load flow was carried out without incorporating SVC or STATCOM in the network. The convergence of load flow was achieved in four iterations, whereas in TPIM was achieved in five iterations. The voltage at each bus and the total power loss is shown in Table 2.

Then, the three-phase load flow is calculated incorporating the proposed SVC and STATCOM models separately to regulate the voltage at bus 5 to be 0.98 pu. In this instance, the total susceptance model is used and the minimum and maximum susceptance limits are considered as -0.25pu and 0.25pu respectively at each phase. The source impedances of STATCOM are $X_{sh} = 0.1 \text{ p.u.}$ each per phase, and the minimum and maximum voltage source limits are 0.95 pu and 1.05 respectively. The power flow result and the voltage control devices parameters are given in Table 3, which are identical to that found in [12].

TABLE 2. UNBALANCE LOAD FLOW RESULT FOR BASE CASE

Bus No.	Phase Voltage (pu)		
	a	b	c
1	$1.060\angle 0.00^\circ$	$1.060\angle -120.00^\circ$	$1.060\angle 120.00^\circ$
2	$1.000\angle -2.02^\circ$	$1.000\angle -121.84^\circ$	$1.000\angle 117.58^\circ$
3	$0.982\angle -4.67^\circ$	$0.988\angle -124.74^\circ$	$0.991\angle 115.38^\circ$
4	$0.981\angle -4.84^\circ$	$0.983\angle -125.05^\circ$	$0.987\angle 114.88^\circ$
5	$0.979\angle -5.96^\circ$	$0.975\angle -124.74^\circ$	$0.960\angle 113.23^\circ$
Total Real Power Losses = 18.72 MW			

TABLE 3. UNBALANCE LOAD FLOW RESULT INCORPORATING SVC AND STATCOM

Bus No.	Phase Voltage (pu)		
	a	b	c
1	$1.060\angle 0.00^\circ$	$1.060\angle -120.00^\circ$	$1.060\angle 120.00^\circ$
2	$1.000\angle -2.04^\circ$	$1.000\angle -121.84^\circ$	$1.000\angle 117.61^\circ$
3	$0.982\angle -4.64^\circ$	$0.989\angle -124.83^\circ$	$0.995\angle 115.37^\circ$
4	$0.981\angle -4.79^\circ$	$0.984\angle -125.16^\circ$	$0.992\angle 114.86^\circ$
5	$0.980\angle -5.76^\circ$	$0.980\angle -125.19^\circ$	$0.980\angle 113.09^\circ$
B_{svc}	0.0500 pu	0.0882 pu	0.1588 pu
E_{sh}	$0.985\angle -5.76^\circ$	$0.989\angle -125.19^\circ$	$0.995\angle 113.09^\circ$
Total Real Power Losses = 18.54 MW			

Finally, the proposed model was tested and compared with other models in different test feeder systems to check the convergence characteristics. The comparative method used for STATCOM is [14] and for SVC is [12]. From Table 4, it can be observed that the developed model has better convergence characteristics than a comprehensive STATCOM and SVC model in conventional TPIM load flow. It was noted that the number of iterations in the proposed model remains the same when incorporating the SVC and STATCOM, while in the comparative models the number of iterations increased. As the convergence of the comparative method is dependent on the initial values of the control parameters, the number of iterations increased as the initial values were changed. For example, the number of iterations for the comparative model increased from 6 to 9 when the initial value of B_{SVC} changed from 0.2pu to 0.05pu.

TABLE 4. COMPARISON OF CONVERGENCE CHARACTERISTICS

IEEE System	Comparative Models		Proposed Models	
	STATCOM Model	SVC Model	STATCOM Model	SVC Model
IEEE 13	9	8	5	5
IEEE 37	6	8	5	5

C. Case Studies on Unbalance Voltage

This study aims to calculate and improve the unbalance voltage using SVC and STATCOM in an unbalanced power system. In reality, the mutual coupling and connected load between phases are not equal, especially in power distribution network, resulting unbalanced voltage between phases. A common method of evaluating the degree of Voltage Unbalance (VU) is to use the National Electrical Manufacturers Association (NEMA) as given in (20). The NEMA standards state that VU should not exceed 1% for three phase induction motor to give rated output [5].

$$VU = \frac{\left| \text{Max.} \left\{ V^{abc} - \frac{1}{3} \sum_{p=a,b,c} V^p \right\} \right|}{\frac{1}{3} \sum_{p=a,b,c} V^p} \times 100 \quad (20)$$

The modified IEEE 37-bus unbalanced radial distribution feeder was used for this study where a voltage regulator was removed, as shown in Fig. 4. In this test feeder, the loads are very unbalanced, and the distribution lines are not transposed.

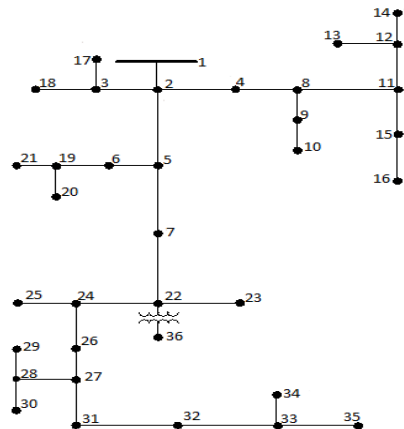

Figure 4. Modified IEEE 37-bus Test Feeder [13]

Three cases of power flow analysis are considered in this part of the investigation. Case 1 is a load flow analysis with no FACTS-control devices. As expected from the load flow result, this system has a higher degree of voltage imbalance, especially from buses 22 to 35, as shown in Fig. 5. It can be also noted from Fig. 7 that the VU counted more than 2.5% (bus 31-34). Case 2 is a load flow analysis with FACTS devices connected to regulate the voltage at the connected bus. A voltage control device was used to regulate bus 7 to have a balanced voltage of 1.01 pu at each phase. In this case, the SVC or STATCOM supply reactivates power at 'phases a and c' and absorbs the reactive power at phase b. It can be noted from Fig. 7 that the VU is reduced to 1.5 %.

In Case 3, one of the voltage control devices was used to reduce the voltage imbalance to be less than 1% in all buses. It was connected to the same bus (bus 7), but with different target voltages at each phase so that the voltage imbalance is limited to 1%. To achieve this limit, the target voltage was set to be $V_a=1.02pu$, $V_b=1.005pu$, and $V_c=1.01pu$. The voltage imbalance is improved and reduced to be a maximum of 0.86% at bus number 34, as shown in Fig. 6 and Fig. 7. This case study indicates that unbalanced control of these devices can further improve the overall VU in the network, especially in active distribution system when considering Optimal Power Flow (OPF).

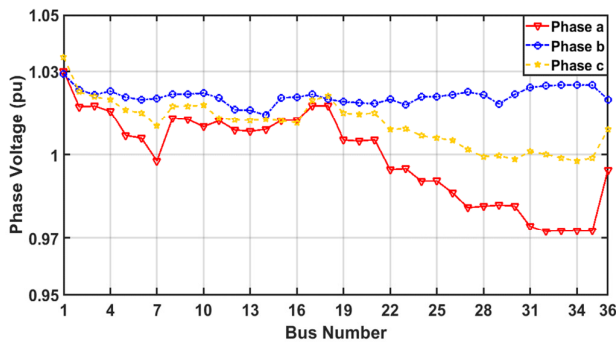

Figure 5. Three Phase Voltage for Case 1

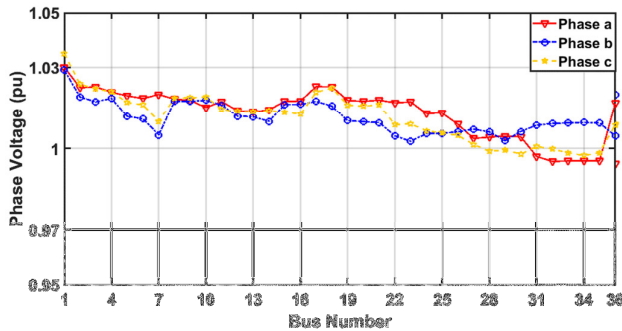

Figure 6. Three Phase Voltage for Case 3

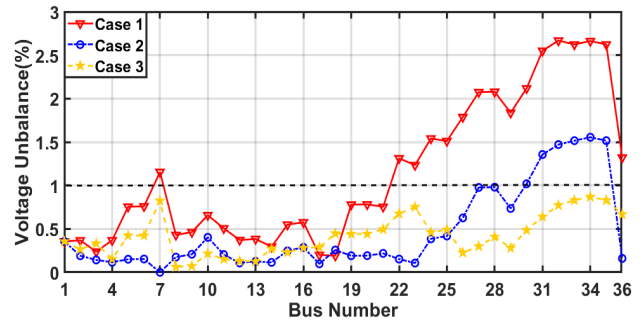

Figure 7. Voltage Unbalance at Each Bus for All Cases

VI. CONCLUSION

This paper presented an innovative unbalanced power flow solution method to apply in unbalanced operation of SVCs and STATCOMs. The method bridges the power and current injection in single platforms, and the hybrid combination solves the problem robustly and efficiently with less computing time demand.

Extended studies with the proposed method suggest that the FACTS devices are not only regulated with the connected bus voltage but also improve the entire power distribution system voltage profiles.

Increased integration of renewable power generators, including photovoltaics to power distribution systems, requires advanced approaches to address unbalanced operating conditions. The proposed method is one of the alternatives that fits for purpose and provides extended opportunities for the optimization of smart power distribution system applications with the presence of increased distributed power generation.

REFERENCES

- [1] F. Shahnia, P. J. Wolfs, and A. Ghosh, "Voltage unbalance reduction in low voltage feeders by dynamic switching of residential customers among three phases," *IEEE Trans. Smart Grid*, vol. 5, no. 3, pp. 1318–1327, 2014.
- [2] N. G. Hingorani, L. Gyugyi, and M. El-Hawary, *Understanding FACTS: concepts and technology of flexible AC transmission systems*, vol. 1. IEEE press New York, 2000.
- [3] X.-P. Zhang, C. Rehtanz, and B. Pal, *Flexible AC transmission systems: modelling and control*. Springer Science & Business Media, 2012.
- [4] T. V. Trujillo, C. R. Fuente-Esquivel, and J. H. T. Hernandez, "Advanced three-phase static VAR compensator models for power flow analysis," *IEE Proceedings-Generation, Transm. Distrib.*, vol. 150, no. 1, pp. 119–127, 2003.
- [5] B. Sereeter, K. Vuik, and C. Witteveen, "Newton Power Flow Methods for Unbalanced Three-Phase Distribution Networks," *Energies*, vol. 10, no. 10, p. 1658, 2017.
- [6] S. Kamel and F. Jurado, "Modeling of STATCOM in load flow formulation," in *Static Compensators (STATCOMs) in Power Systems*, Springer, 2015, pp. 405–435.
- [7] F. Rabea, S. Kamel, F. Jurado, and O. Abdel-Rahim, "Implementation of a simplified SVC model into Newton-Raphson load flow algorithm," in *Innovative Trends in Computer Engineering (ITCE)*, 2018 International Conference on, 2018, pp. 374–379.
- [8] J. M. Maza-Ortega, E. Acha, S. García, and A. Gomez-Exposito, "Overview of power electronics technology and applications in power generation transmission and distribution," *J. Mod. Power Syst. Clean Energy*, vol. 5, no. 4, pp. 499–514, 2017.
- [9] P. A. N. Garcia, J. L. R. Pereira, S. Carneiro, M. P. Vinagre, and F. V. Gomes, "Improvements in the representation of PV buses on three-phase distribution power flow," *IEEE Trans. Power Deliv.*, vol. 19, no. 2, pp. 894–896, 2004.

- [10] S. Kamel, M. Abdel-Akher, and F. Jurado, "Improved NR current injection load flow using power mismatch representation of PV bus," *Int. J. Electr. Power Energy Syst.*, vol. 53, pp. 64–68, 2013.
- [11] P. A. N. Garcia, J. L. R. Pereira, S. Carneiro, V. M. da Costa, and N. Martins, "Three-phase power flow calculations using the current injection method," *IEEE Trans. Power Syst.*, vol. 15, no. 2, pp. 508–514, 2000.
- [12] E. Acha, C. R. Fuerte-Esquivel, H. Ambriz-Perez, and C. Angeles-Camacho, *FACTS: modelling and simulation in power networks*. John Wiley & Sons, 2004.
- [13] W. H. Kersting, "Radial distribution test feeders," in *Power Engineering Society Winter Meeting*, 2001. IEEE, 2001, vol. 2, pp. 908–912.
- [14] J. M. Ramirez, J. M. Gonzalez-Lopez, J. C. Rosas-Caro, R. Tapia-Olvera, J. M. Lozano, and A. Valderrabano-Gonzalez, "Study of STATCOM in abc Framework," in *Static Compensators (STATCOMs) in Power Systems*, Springer, 2015, pp. 371–403.