

In vitro study of the deployment performance of 3D printed stents in the diseased artery with the lipid arterial plaques

Abdulsalam, M.; Feng, J.; Garrard, R.; Attallah, M. M.; Serracino-Inglott, F.; Zhao, L.

DOI:

[10.1016/j.prostr.2022.12.077](https://doi.org/10.1016/j.prostr.2022.12.077)

License:

Creative Commons: Attribution-NonCommercial-NoDerivs (CC BY-NC-ND)

Document Version

Publisher's PDF, also known as Version of record

Citation for published version (Harvard):

Abdulsalam, M, Feng, J, Garrard, R, Attallah, MM, Serracino-Inglott, F & Zhao, L 2023, 'In vitro study of the deployment performance of 3D printed stents in the diseased artery with the lipid arterial plaques', *Procedia Structural Integrity*, vol. 42, pp. 608-613. <https://doi.org/10.1016/j.prostr.2022.12.077>

[Link to publication on Research at Birmingham portal](#)

General rights

Unless a licence is specified above, all rights (including copyright and moral rights) in this document are retained by the authors and/or the copyright holders. The express permission of the copyright holder must be obtained for any use of this material other than for purposes permitted by law.

- Users may freely distribute the URL that is used to identify this publication.
- Users may download and/or print one copy of the publication from the University of Birmingham research portal for the purpose of private study or non-commercial research.
- User may use extracts from the document in line with the concept of 'fair dealing' under the Copyright, Designs and Patents Act 1988 (?)
- Users may not further distribute the material nor use it for the purposes of commercial gain.

Where a licence is displayed above, please note the terms and conditions of the licence govern your use of this document.

When citing, please reference the published version.

Take down policy

While the University of Birmingham exercises care and attention in making items available there are rare occasions when an item has been uploaded in error or has been deemed to be commercially or otherwise sensitive.

If you believe that this is the case for this document, please contact UBIRA@lists.bham.ac.uk providing details and we will remove access to the work immediately and investigate.



23 European Conference on Fracture - ECF23

In vitro study of the deployment performance of 3D printed stents in the diseased artery with the lipid arterial plaques.

M. Abdulsalam^a, J. Feng^{a*}, R. Garrard^b, MM. Attallah^b, F Serracino-Inglott^c, L. Zhao^d

^aDepartment of Science and Environment, Manchester Metropolitan University, Manchester, M1 5GD

^bSchool of Metallurgy and Materials, University of Birmingham, Birmingham, B15 2TT, UK

^cVascular Department, Manchester University NHS Foundation Trust, M13 9WL, UK

^dWolfson School of Mechanical, Electrical and Manufacturing Engineering, Loughborough University, Epinal Way, Loughborough, LE11 3TU, UK

Abstract

Atherosclerotic plaque is one of the arterial diseases which builds up in the arterial wall and can be identified by the composition of the plaque. Atherosclerosis causes the narrowing or occlusions of the arterial lumen leading to cardiovascular event. Percutaneous (keyhole) endovascular stenting has become the most common revascularisation method due to its minimum invasive nature and low complication rate. The stents, mostly fabricated by laser machines, have uniform geometries which are not ideal to treat the diseased arteries with lesion-specific properties. In addition, the effect of arterial plaque compositions on the performance of stents is not fully investigated. In this study, the deployment performance of the stents with the varied design, made of the 316L stainless steel and fabricated by additive manufacturing (AM) technology, were investigated. An in vitro experiment was conducted to test the influence of the atherosclerotic plaque compositions at 55% stenosis on the commercial and AM fabricated stents. Two artificial plaques (lipid and calcified) were prepared manually, and their mechanical testing were conducted using an unconfined compression test. Two types of stents, printed and commercial stents, were used to treat the diseased artificial artery, and the data of the pressure and diameter were collected simultaneously when the stent inflation pressure was applied. The results show that the mechanical property of the artificial lipid plaques was very similar to the real lipid plaque that observed from clinical study. From the deployment performance test for these two types of stents, it was observed that as the pressure inside of balloon increases, the diameters measured at the external wall of the artificial artery also increase when the pressure is above 4 atm. Overall, there is a close linear relationship between pressure and arterial wall movement with lipid plaque in both printed and commercial stents though that the stent made of AM technology is less flexible and has lower elastic property than the commercial one

© 2022 The Authors. Published by Elsevier B.V.

This is an open access article under the CC BY-NC-ND license (<https://creativecommons.org/licenses/by-nc-nd/4.0>)

Peer-review under responsibility of the scientific committee of the 23 European Conference on Fracture – ECF23

Keywords: Lipid Plaque, Additive Manufacturing, Stents

*Corresponding author. Tel.: +44 (0)161 247 1650

Email address: J.Feng@mmu.ac.uk

1. Introduction

Cardiovascular diseases are one of the major causes of death in the world, which occurs when there are disorders between the heart and blood vessels (Chai et al., 2014). These disorders lead to several diseases such as coronary heart disease, stroke, aortic disease, and Peripheral Arterial Disease (PAD) (Akyildiz et al., 2014). Arterial plaque is one of the common serious diseases in the cardiovascular system which their main compositions include lipid core

(LC), calcium (Ca), and collagen (Col) (Bentzon et al., 2014). Arterial plaques could mainly be classified into stable and vulnerable plaques. Stable plaques could be characterized with thick fibrous cap (FC) and less amount of LC, while vulnerable plaques are agreed to have very thin FC with large amount of LC (Butcovan et al., 2016). These plaques, with time, could cause stenosis which reduces or limits in blood flow leading to heart failure in coronary, stroke in carotid and PAD. PAD hinders blood flow in the arteries of the arms and legs (OLin et al., 2010). If it is untreated, it might result ulcerations and gangrene which may require limb amputation (Ouriel, 2001).

Several invasive and non-invasive approaches have been proposed to revascularize the occluded artery such as balloon stenting, surgical bypass and atherectomy. In cases of PAD, most revascularization measures involve Peripheral Artery (PA) stent implantation (Henery et al., 2000). Stenting is mechanical method, which depends on the cardiologist balloon pressure. The exerts of pressure rely on the geometry of blood vessel, plaque type, and the characteristics of each artery component (Henery et al., 2000). In addition, the range of balloon expansion pressures is given by producers, which is typically less than 12 atm, however, clinicians are usually chosen the stent expansion pressure based on their experience and plaque type, which may range between 10–17 atm (Pache et al., 2003). It has been observed that the composition and the material properties of plaques differ considerably as plaque growths and these properties could be evaluated using imaging techniques (Abdulsalam and Feng, 2021). Moreover, there are several studies (Salunke et al., 2001) propose that various plaques might comply differently with similar stenting procedure.

In this study, we aim to investigate the response of stents with different plaque compositions using in vitro experiment. Number of attempts have been done to fabricate the arterial artificial plaques such as Guo et al., (2013); Abdulsalam and Feng, (2019, 2021); Razi et al., (2022) to investigate the effect of the plaques on arterial system. However, none of those studies tested the biomechanical property of their artificial plaques though it is the key factor of research in biomechanics. In this study, two types of artificial plaques (lipid and calcified plaques) fabricated using the method demonstrated by Abdulsalam and Feng, (2019) and tested using Miller (2005) approach. The two types of stainless-steel stents (V-bend and U-bend), made by using AM techniques, and commercial zigzag stents are implemented into in-vitro arterial system to investigate the effect of plaque composition on the deployment performance of the stents with the varied design.

2. Method

The artificial plaques were firstly prepared using the method introduced in Abdulsalam and Feng (2019). Its characteristics are illustrated in table 1 and its dimensions were 25mm length, 4.5mm wide and 55% blockage degree, see Fig. 1c and Fig. 3. Secondly, these two plaques were tested by unconfined compression test using Miller, (2005) method to ensure there is no slip boundary condition. In this method, coarse-sand papers were cut and mounted between the top and the bottom cylindrical plates of the machine. Thirdly, the specimen samples were fabricated with 30mm diameter, $\cong 10$ mm height and $\cong 100\mu\text{m}$ FC thickness for lipid plaque and $\cong 150\mu\text{m}$ for calcified plaque specimens, see Fig. 2a & b, then left them for 24 hours to ensure their thickness. The Ca and LC were put in the bottom of the FC specimen sample in the second day, and they were covered by the same material of the specimen sample, then left them for 24 hours. The compression testing was performed to 30% strain to obtain stress vs. strain relations at 5.0 mm/min of speed test. 200 N and 1000 N load cell were applied on lipid and calcified specimen, respectively, and 0.26 preload with displacement range 10 mm was used. The force and the displacement graph was converted to the engineering stress and strain then to true stress and strain using the following equations (Arasaratnam et al., 2011):

$$\text{True Strain} = \ln(1 + \text{Engineering Strain}) \quad (1)$$

$$\text{True Stress} = \text{Engineering Stress} \times (\text{True Strain}) \quad (2)$$

Table 1. The percentage of plaque compositions for lipid and calcified plaques

Plaque Type	Fibrous Cap (μm)	Lipid Core (%)	Calcium (%)	Collagen (%)
Lipid Plaque	100	$\cong 98$	0	2
Clcified Plaque	150	0	$\cong 50$	$\cong 50$

Two types of stents, 3D printed V-Shape (Printed at university of Birmingham, UK) and commercial (Abbott, USA), were used to investigate the effect of lipid plaque on the stent behaviour. The 3D printed stent was fabricated using Selective Laser Melting (SLM), see Fig. 2c, while the commercial stent was from Multi-Link RX Ultra of Abbott with 100 μ m strut thickness.

Simultaneously, the 5.2mm diameter, using 2mm crystals (Sonometrics Corporation, Canada), and pressure, from balloon inflation device readings, were measured from 2 to 14 atm. The lipid plaque was located in the middle of the artificial PA using small medical spoon. The coronary stent system (Abbott, USA) with the stent was connected to the balloon inflation device (Cook Sphere, UK), then it was inserted inside the artificial PA on the location of the plaque. The balloon inflation pressure was applied from 1 to 10 atm for printed stent and from 1 to 14 atm for commercial stent simultaneously with change of diameter in order to obtain the relationship between pressure and diameter, see Fig. 3. The calcified plaque data, however, cannot be achieved because its stiffness was too hard for the inflation process.

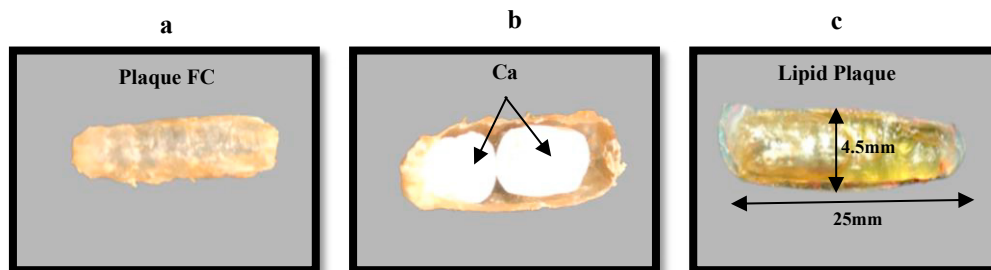

Fig. 1. Shows how plaque was prepared. (a) represents the plaque fibrous cap. (b) demonstrates the position of calcium on the calcified plaque. (c) illustrates the lipid plaque. FC and Ca abbreviations mean fibrous cap and calcium, respectively.

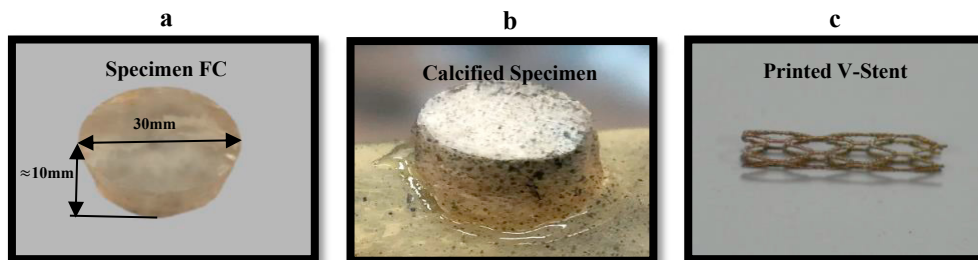

Fig. 2. shows plaque preparation specimen. (a) is the fibrous cap specimen. (b) is an example of the whole plaque specimen. (d) shows the printed V shape printed stent

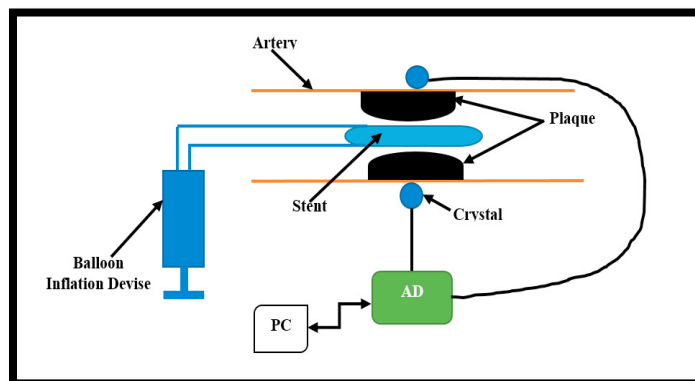

Fig. 3. Shows the in vitro experiment setup. The plaque was mounted in the middle of the artificial blood vessel and its stenosis was 55%. AD represents the accusation data, and the PC means the personal computer. The balloon inflation device exerts pressure from 0 to 14 ATM. The data of diameter and pressure was collected simultaneously.

3. Results

3.1. Mechanical Properties of the Plaques

Fig. 4a and 4b show the loading and unloading relationship between stress and strain of the artificial arterial calcified and lipid plaques obtained from unconfined compression test machine, respectively. There are two peaks, illustrated by arrows, in calcified plaque specimen (Fig. 4a), while one peak observed in lipid plaque. As can be seen in Fig. 4a, the value of Young's modulus (E), which is 11.28MPa, is too high compared to the real calcified plaque observed from clinical studies, while in arterial lipid plaque specimen (Fig. 4b), its value is relatively close to the real lipid plaque at 0.2057MPa (Teng et al., 2014). The result of lipid plaque gives promising view since the E value is comparatively close to the real lipid plaque.

3.2. Pressure and Diameter Relationship

The relationship between balloon pressure and arterial wall movement diameter of V-printed and commercial stents is illustrated in Fig. 5a and 5b, respectively. It is obvious that there is a change of arterial wall movement with a change of balloon pressure for both stents. This finding shows that printed and commercial stents behaviour are relatively similar from 0 to 4 atm, but from 4 to 8 atm, the diameter behaviour of printed one is higher than commercial one. However, from 8 atm upward, the diameter behaviour of commercial stent remains almost stable, whereas a noticeable increase of printed stent diameter is observed.

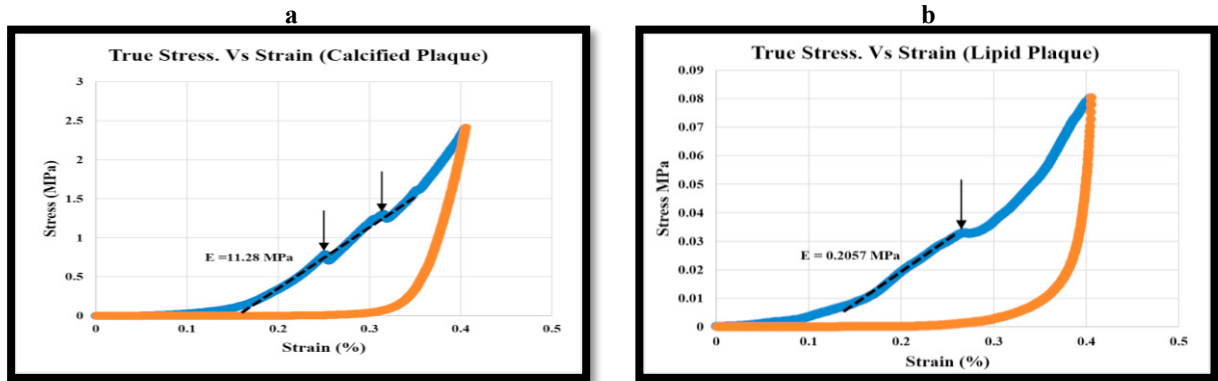

Fig. 4. The loading and unloading compression test for lipid and calcified plaque specimens. (a) shows the relationship between stress and strain of the calcified specimen. The two peaks means that the plaque starts to ruptur with increase of loading. (b) illustrates the relationship between stress and strain of lipid specimen. The arrow indicates the ruptur of the plaque. The E value of calcified plaque is far higher, while the E value of lipid is relatively close to the real one.

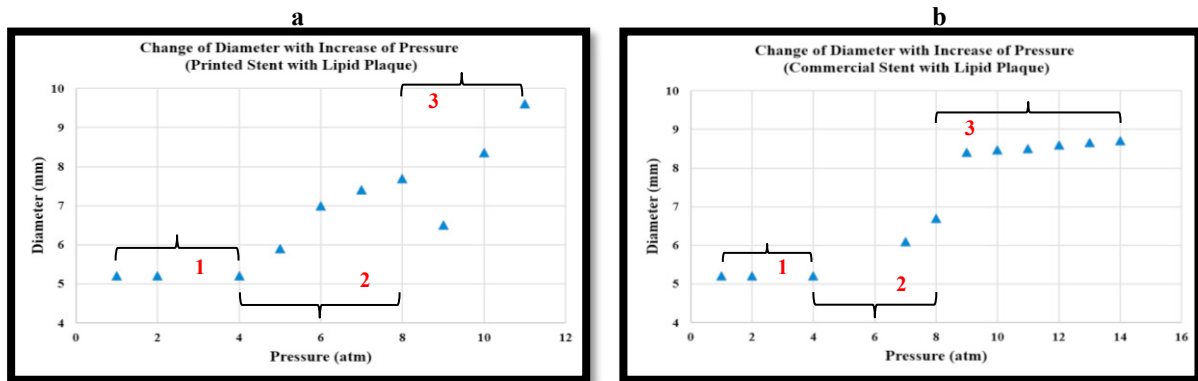

Fig. 5 shows the relationship between arterial wall movement diameter and balloon pressure. (a) depicts the change of wall movement arterial diameter with increase of balloon pressure of V-printed stent. (b) demonstrates the commercial stent relationship between change of arterial diameter and balloon pressure. Stage 1, no change in diameter, Stage 2 a noticeable increase in diameter, stage 3 the maximum diameter value.

4. Discussion

The present study attempts to investigate the behaviour of arterial wall movement diameter with balloon stenting pressure of the printed V-stent and commercial stent for calcified and lipid plaques. These plaques were tested to evaluate their material properties before applying them on the in vitro experiment. The two peaks that observed in Fig. 4a and one peak in Fig. 4b indicate the rupture of the fibrous cap sample which increase with increase of machine load. The reason of these ruptures is because of material properties of plaque. In case of calcified plaque specimen, when the load of machine applied on the specimen circumference which includes FC and Ca (below the FC), the FC will have a high stress (Li et al., 2005) caused by machine load on the top and Ca in the bottom leading to fracture of the FC and it continues to rupture until the Ca becomes flatten. However, in the lipid plaque sample, there was no much stress on the FC due to the existence of lipid and thin of FC ((Cheng et al., 1993); (Li et al., 2005); (Alegre-Martínez et al., 2019)). When the FC ruptures, the lipid releases from the sample then the shape of the FC sample deforms and flatten. In addition, the result in Fig. 4b highlight that the E value of arterial lipid plaque is comparatively close to the real one that observed from the clinical study. This clinical study investigated the biomechanical properties of the arterial carotid plaque (Teng et al., 2014). They found that the E median value of lipid is ranging between 0.1044, 0.2207 and 0.5334MPa, which its average value is 0.28616MPa. This average value is close to the one observed in this study (0.2057MPa). However, the E of the calcified plaque is far higher than the one that observed from clinical study. This can be justified by the following reasons. Firstly, the calcium of calcified plaque was prepared including 50% Ca and 50% Col with 150 μ m FC thickness. Secondly, its FC thickness is too thick, and it mostly contains of Col. Thirdly, several studies such as Li et al., (2018) and Abdulsalam and Feng (2021) prove that the stiffness of the plaque increases with the increase of the Col proportion. Finally, the existence of Col in the Ca and in the FC lead to increase the stiffness of the specimen sample and therefore increase the value of E . This phenomenon needs further investigation.

With advent of technology, AM regards as an innovative technology, which can be used to manufacture stents for treating unhealthy blood vessel (Langi et al., 2022). From these two graphs Fig. 5 a&b, we can see (1) before 4atm, for both stents made of AM technique and commercial stents, the diameter of arterial wall has not changed because the stents have not been touched the inside wall of plaque and therefore, there is no deformation of wall, see Fig. 3. However, after 4 atm (2), for the commercial one, the diameter increases faster as the pressure increase, which demonstrates that commercial is more elastic and flexible than the printed one during the deployment stage. At 10 atm (3), the diameter increases to the maximum value at 8.36 mm for printed stent and 8.4 for commercial stent, while at 9 atm for the printed one, there is a decrease of diameter which imply that the 3D printed one might have the recoil during the deployment stage. This finding demonstrates that the relationship between balloon pressure and arterial diameter in both stents are nearly close to each other, which can possibly be argued that printed stent could potentially be used in the cardiovascular application. To sum up, printed stent may offer promising approach to print different types and shapes of stents to deal with complex geometry of plaque location and could treat severe blocked blood vessels.

To increase the capability of this study, different types of plaques with their material properties should be investigated. Moreover, this study applied only printed V-stent, other types of stents is strongly recommended in order to explore which type and shape of stent is close than others to the commercial stent. Finally, patient-specified plaque with patient-specified stent should also be studied to give a clearer picture of using printed stents.

5. Conclusion

This study has investigated the mechanical properties of lipid core plaque and applied it in in vitro experiment to test the behaviour of printed V-stent and commercial one. Our findings indicate that the material properties of artificial lipid plaque, prepared at our physiological fluid dynamics lab, are similar to the one that observed from clinical studies. Also, it has been observed that there is a strong correlation between expanding balloon pressure and arterial diameter for both stents. Although the stent made of AM technology is less flexible and has the lower elastic property than the commercial one, the V-printed stent that fabricated by AM technology has the potential to be used to treat the blocked arteries in future.

Acknowledgement

The work is supported by the funding from the Engineering and Physical Science and Research Council (Grant No: EP/R001901/1).

References

- Abdulsalam, M., Feng, J., 2019. Distinguish the stable and unstable plaques based on arterial waveform analysis. *Procedia Structural Integrity* 15, 2–7.
- Abdulsalam, M., Feng, J., 2021. The composition of vulnerable plaque and its effect on arterial waveforms. *Journal of the Mechanical Behavior of Biomedical Materials* 119, 104491.
- Akyildiz, A., Speelman, L., Gijssen, F., 2014. Mechanical properties of human atherosclerotic intima tissue. *Journal of Biomechanics* 47, 773 – 783
- Alegre-Martínez, C., Choi, K. S., Tammisola, O., McNally, D., 2019. On the axial distribution of plaque stress: Influence of stenosis severity, lipid core stiffness, lipid core length and fibrous cap stiffness. *Medical Engineering and Physics* 68, 76–84.
- Arasaratnam, P., Sivakumaran, K. S., Tait, M. J., 2011. True Stress-True Strain Models for Structural Steel Elements. *ISRN Civil Engineering* 2011 1–11.
- Bentzon, J. F., Otsuka, F., Virmani, R., Falk, E., 2014. Mechanisms of plaque formation and rupture. *Circulation Research* 114(12), 1852–1866.
- Butcovan, D., Mocanu, V., Baran, D., Ciurescu, D., Tinica, G., 2016. Assessment of vulnerable and unstable carotid atherosclerotic plaques on endarterectomy specimens. *Experimental and Therapeutic Medicine* 11(5), 2028–2032.
- Chain, C., Speelman, L., Oomens, O., Baaijens, F., 2014. Compressive mechanical properties of atherosclerotic plaques Indentation test to characterise the local anisotropic behaviour. *Journal of Biomechanics* 47, 784 – 792
- Cheng, G. C., Loree, H. M., Kamm, R. D., Fishbein, M. C., Lee, R. T., 1993. Distribution of Circumferential Stress in Ruptured and Stable Atherosclerotic Lesions A Structural Analysis With Histopathological Correlation. *Circulation* 87, 1179 – 1187
- Henery, M., Klonaris, M., Amor, M., Henry, I., Tzvetanov, M., 2000. Which Stent for Which Lesion in Peripheral Interventions?. *Tex Heart Inst J* 27,119-126.
- Langi, E., Zhao, L. G., Jamshidi, P., Attallah, M., Silberschmidt, V. v., Willcock, H., Vogt, F., 2022. A comparative study of microstructures and nanomechanical properties of additively manufactured and commercial metallic stents. *Materials Today Communications* 31,103372
- Li, J., Wu, H., Hao, Y., Yao, X., 2019. Unstable Carotid Plaque is Associated With Coagulation Function and Platelet Activity Evaluated by Thrombelastography. *Journal of Stroke and Cerebrovascular Diseases* 28(11), 104336.
- Li, Z. Y., Howarth, S., U-King-Im, J., Gillard, J. H., 2005. Atheroma: Is calcium important or not? A modelling study of stress within the atheromatous fibrous cap in relation to position and size of calcium deposits. *Annual International Conference of the IEEE Engineering in Medicine and Biology - Proceedings* 7, 2236–2239.
- Miller, K., 2005. Method of testing very soft biological tissues in compression. *Journal of Biomechanics* 38(1), 153–158.
- OLin, J., DO, MD, B., 2010. Peripheral artery disease: current Insight Into the Disease and Its Diagnosis and Management. *Mayo Clin Proc* 85(7), 1–15.
- Ouriel, K., 2001. Peripheral arterial disease. *THE LANCET* 358, 1257–1264.
- Pache, J., Kastrati, A., Mehilli, J., Schühlen, H., Dotzer, F., Hausleiter, J., Fleckenstein, M., Neuman, F. J., Sattelberger, U., Schmitt, C., Müller, M., Dirschinger, J., Schömig, A., 2003. Intracoronary stenting and angiographic results: Strut thickness effect on restenosis outcome (ISAR-STEREO-2) trial. *Journal of the American College of Cardiology* 41(8), 1283–1288.
- Razzi, F., Lovrak, M., Gruzdyte, D., Hartog, Y D., Duncker, D J., van Esch, J H., Steijn, V., Beusekom, H M M., 2022. An Implantable Artificial Atherosclerotic Plaque as a Novel Approach for Drug Transport Studies on Drug-Eluting Stents. *Adv. Healthcare Mater* 102 (6), 1905-1914.
- Salunke, N., Topoleski, L. D. T., Humphrey, J. D., Mergner, W J., 2001. Compressive stress-relaxation of human atherosclerotic plaque. *Mater Res* 55, 236-241.
- Teng, Z., Zhang, Y., Huang, Y., Feng, J., Yuan, J., Lu, Q., Sutcliffe, M. P. F., Brown, A. J., Jing, Z., Gillard, J. H., 2014. Material properties of components in human carotid atherosclerotic plaques: A uniaxial extension study. *Acta Biomaterialia* 10(12), 5055–5063.